



CIL 100 P - CIL 125 P

INSTRUCTION MANUAL

In - Line Centrifugal Fan

THIS MANUAL MUST ALWAYS BE READILY AVAILABLE

GENERAL PRECAUTIONS

IT IS RECOMMENDED THAT YOU READ THE FOLLOWING INSTRUCTIONS VERY CAREFULLY BEFORE USING THE PRODUCT. THE MANUFACTURER WILL NOT BE HELD RESPONSIBLE AND DECLINES ANY AND ALL LIABILITY FOR DAMAGE CAUSED TO PERSONS OR PROPERTY DUE TO IMPROPER USE WITH REFERENCE TO THE PRECAUTIONS OUTLINED IN THIS MANUAL.

- The manual explains how to install correctly, use and perform maintenance on the product. Following these instructions will ensure that the product will be electrically and mechanically reliable and will extend its service life.
- Do not use this product for any purpose other than that for which it was designed and as illustrated herein.
- After removing the product from the packing, make sure that it has not been damaged. If doubts arise, immediately contact professionally qualified personnel.
- Do not leave packing parts within the reach of children or unskilled people. Do not dump any hazardous parts into the environment (polystyrene, plastic, polypropylene, etc.).
- If the product is dropped or badly knocked, immediately contact qualified personnel (authorised dealer, service centre or manufacturer) to check that the product operates correctly.
- The use of any electrical device requires compliance with some basic rules which are listed below:
 - do not touch the device with moist or wet parts of the body (hands, feet).
 - do not allow the product to be operated by children or unskilled people.
- Connect the product to the mains electricity supply or electrical outlet only if:
 - your electrical voltage and frequency corresponds to those shown on the rating label.
 - the capacity of your electricity supply is sufficiently powerful to operate the product at its maximum power.If not, contact professionally qualified personnel.
- It is recommended that the product is switched off when not in use.
- Before carrying out any maintenance or cleaning, switch off the product and disconnect it from the mains electricity supply.
- If a fault, malfunction or anomaly of any type occurs, make the device inoperative (by turning off the switch and by disconnecting it from the mains electricity supply) and immediately contact qualified personnel.
Always request original spare parts to effect any repairs.
- If the product needs to be removed, turn off the main network circuit-breaker and then disconnect the device from that network.
Place the device in a safe location far from children and/or unskilled people.
- All electrical connections must comply with current BS7671 wiring regulations.

SPECIAL PRECAUTIONS

- The product is professionally manufactured and complies with the current standards regarding electrical equipment.
- The fans comply with BSEN60335; with the Low Voltage Directive; with EC Directive EMC 89/336 for the Suppression of Radio Interference.
- Do not use the product at an ambient temperature greater than 40 °C (104 °F).
- Do not allow the product to be exposed to atmospheric agents (rain, sun, snow, etc.).
- Possible product applications are indicated in the attached illustrations.
- Do not place the device or relative parts in water or liquids, except where indicated in the cleaning and maintenance section.
- When cleaning or performing routine maintenance, check the condition of the device.
- To avoid the risk of fire, do not use the product in the presence of inflammable substances or vapours such as alcohol, insecticides, gasoline, etc.
- The air or fumes being extracted must be clean and free from greasy particles, soot, chemical and corrosive agents, inflammable or explosive mixes (If these substances are treated, contact an authorised dealer to consult the specific range of explosion-proof products).
- **The device must be installed by professionally qualified personnel. Incorrect installation can cause damage to people, animals or property, for which the manufacturer cannot be held liable.**
- The product must be connected to the electricity supply via a fixed wired and fused (3 amp) spur incorporating a double pole switch with contact openings of at least 3 mm.
- To ensure optimum operation, do not block the air intake and delivery vents.
- For devices operating in ducts, make sure that the duct is not blocked.
- For optimum operation, ensure that the product is installed at a minimum height of 2.30 m above the ground.
- The room where the device is located must be adequately ventilated to ensure correct operation.
- If the device is sited in a room containing a fuel burning appliance, the installer must ensure that air replacement is adequate both for the device and the fuel burning appliance.
- The device should not be used as an activator for water heaters, stoves, etc.
- The device must not exhaust into ducts designed to evacuate fumes coming from the combustion in stoves or other combustion-powered devices.
- The device must have a single duct (for its exclusive use) or exhaust directly outdoors.

INSTALLATION

None of this range weighs more than 20 kg, i.e. one person can move them.

While moving or installing the product, gloves or similar protection should be worn in order to prevent accidents for your own and other people's safety.

Install the fan according to Fig 1 and Fig 2.

Fasten your appliance steadily by means of the wall mounting brackets.

Use clamps if the unit is installed in rigid duct (available from your supplier).

The fan has been designed for in-line installation. It can be also mounted with free inlet (in this case a protection guard, available from your supplier, must be installed to prevent the risk of access to the moving parts), while the outlet must always be ducted.

Employ a cable type as per Fig 3.

For the connection see Fig 4.

Cut the grommet, so that it can adhere to the cable diameter perfectly.

Provide proper electric protections according to the installed model.

After the appliance has started, check whether:

- the rotation direction is correct, i.e. according to the indication on the contact box
- the electric absorption corresponds to the rating
- excessive vibrations can compromise the appliance stability.

Should the appliance be connected through a speed controller, make sure that is suitable for the power of the appliance.

FIG. 1

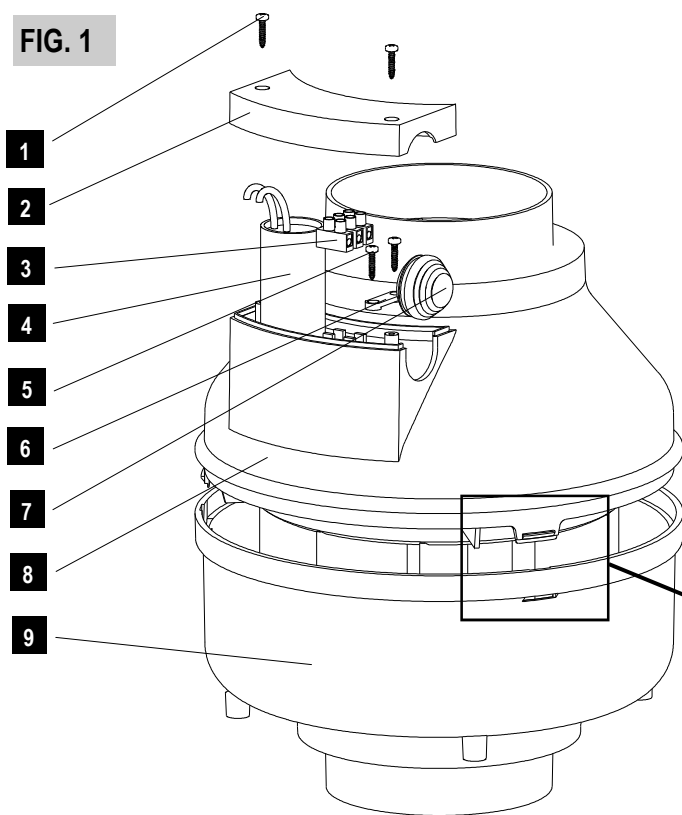

LEGEND:

- 1 COVER SCREW
- 2 COVER
- 3 TERMINAL BLOCK
- 4 CAPACITOR
- 5 SCREWS FOR CABLE CLAMP
- 6 CABLE CLAMP
- 7 GROMMET
- 8 UPPER HOUSING
- 9 LOWER HOUSING

FIG. 2

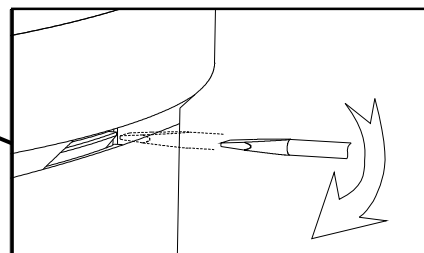
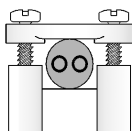

FIG. 3

H03 VV-F



H03 VV H2-F

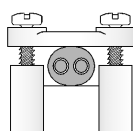
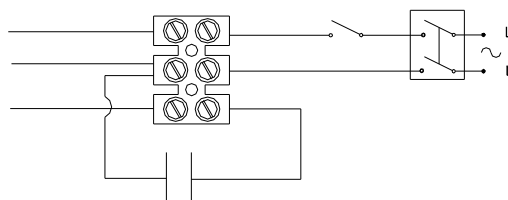

FIG. 4



MAINTENANCE AND CLEANING

The motor and the fan blades shall be periodically controlled, usually afterwards every six months of continuous operation.

Maintenance shall be carried out just by qualified personnel.

Before any maintenance or cleaning operation, disconnect the appliance from the main power supply.

To clean the inside of the fan, use a soft brush taking care not to cause any damage to the electrical wiring.

During the normal cleaning operations, check the integrity of all appliance parts.

Vectaire Ltd.

Lincoln Road, Cressex Business Park, High Wycombe, Buckinghamshire, HP12 3RH, UK

Tel. +44 (0) 1494 522333 Fax +44 (0) 1494 522337



CIL 150 P - CIL 160 P

INSTRUCTION MANUAL

In - Line Centrifugal Fan

THIS MANUAL MUST ALWAYS BE READILY AVAILABLE

GENERAL PRECAUTIONS

IT IS RECOMMENDED THAT YOU READ THE FOLLOWING INSTRUCTIONS VERY CAREFULLY BEFORE USING THE PRODUCT. THE MANUFACTURER WILL NOT BE HELD RESPONSIBLE AND DECLINES ANY AND ALL LIABILITY FOR DAMAGE CAUSED TO PERSONS OR PROPERTY DUE TO IMPROPER USE WITH REFERENCE TO THE PRECAUTIONS OUTLINED IN THIS MANUAL.

- The manual explains how to install correctly, use and perform maintenance on the product. Following these instructions will ensure that the product will be electrically and mechanically reliable and will extend its service life.
- Do not use this product for any purpose other than that for which it was designed and as illustrated herein.
- After removing the product from the packing, make sure that it has not been damaged. If doubts arise, immediately contact professionally qualified personnel.
- Do not leave packing parts within the reach of children or unskilled people. Do not dump any hazardous parts into the environment (polystyrene, plastic, polypropylene, etc.).
- If the product is dropped or badly knocked, immediately contact qualified personnel (authorised dealer, service centre or manufacturer) to check that the product operates correctly.
- The use of any electrical device requires compliance with some basic rules which are listed below:
 - do not touch the device with moist or wet parts of the body (hands, feet).
 - do not allow the product to be operated by children or unskilled people.
- Connect the product to the mains electricity supply or electrical outlet only if:
 - your electrical voltage and frequency corresponds to those shown on the rating label.
 - the capacity of your electricity supply is sufficiently powerful to operate the product at its maximum power.
- If not, contact professionally qualified personnel.
- It is recommended that the product is switched off when not in use.
- Before carrying out any maintenance or cleaning, switch off the product and disconnect it from the mains electricity supply.
- If a fault, malfunction or anomaly of any type occurs, make the device inoperative (by turning off the switch and by disconnecting it from the mains electricity supply) and immediately contact qualified personnel.
Always request original spare parts to effect any repairs.
- If the product needs to be removed, turn off the main network circuit-breaker and then disconnect the device from that network.
Place the device in a safe location far from children and/or unskilled people.
- All electrical connections must comply with current BS7671 wiring regulations.

SPECIAL PRECAUTIONS

- The product is professionally manufactured and complies with the current standards regarding electrical equipment.
- The fans comply with BSEN60335; with the Low Voltage Directive; with EC Directive EMC 89/336 for the Suppression of Radio Interference.
- Do not use the product at an ambient temperature greater than 40 °C (104 °F).
- Do not allow the product to be exposed to atmospheric agents (rain, sun, snow, etc.).
- Possible product applications are indicated in the attached illustrations.
- Do not place the device or relative parts in water or liquids, except where indicated in the cleaning and maintenance section.
- When cleaning or performing routine maintenance, check the condition of the device.
- To avoid the risk of fire, do not use the product in the presence of inflammable substances or vapours such as alcohol, insecticides, gasoline, etc.
- The air or fumes being extracted must be clean and free from greasy particles, soot, chemical and corrosive agents, inflammable or explosive mixes (If these substances are treated, contact an authorised dealer to consult the specific range of explosion-proof products).
- **The device must be installed by professionally qualified personnel. Incorrect installation can cause damage to people, animals or property, for which the manufacturer cannot be held liable.**
- The product must be connected to the electricity supply via a fixed wired and fused (3 amp) spur incorporating a double pole switch with contact openings of at least 3 mm.
 - To ensure optimum operation, do not block the air intake and delivery vents.
- For devices operating in ducts, make sure that the duct is not blocked.
- For optimum operation, ensure that the product is installed at a minimum height of 2.30 m above the ground.
- The room where the device is located must be adequately ventilated to ensure correct operation.
- If the device is sited in a room containing a fuel burning appliance, the installer must ensure that air replacement is adequate both for the device and the fuel burning appliance.
- The device should not be used as an activator for water heaters, stoves, etc.
- The device must not exhaust into ducts designed to evacuate fumes coming from the combustion in stoves or other combustion-powered devices.
- The device must have a single duct (for its exclusive use) or exhaust directly outdoors.

INSTALLATION

None of this range weighs more than 20 kg, i.e. one person can move them.

While moving or installing the product, gloves or similar protection should be worn in order to prevent accidents for your own and other people's safety. Install the fan according to Fig 1.

Fasten your appliance steadily by means of the wall mounting brackets.

Use clamps if the unit is installed in rigid duct (available from your supplier).

The fan has been designed for in-line installation. It can be also mounted with free inlet (in this case a protection guard, available from your supplier, must be installed to prevent the risk of access to the moving parts, see Fig 2), while the outlet must always be ducted.

Employ a cable type as per Fig 3.

For the connection see Fig 4 .

Cut the grommet, so that it can adhere to the cable diameter perfectly.

Provide proper electric protections according to the installed model.

After the appliance has started, check whether:

- the rotation direction is correct, i.e. according to the indication on the contact box
- the electric absorption corresponds to the rating
- excessive vibrations can compromise the appliance stability.

Should the appliance be connected through a speed controller, make sure that is suitable for the power of the appliance.

- LEGEND:
- | | | | |
|---|------------------------|----|--------------------------------|
| 1 | COVER SCREW | 8 | UPPER HOUSING |
| 2 | COVER | 9 | LOWER HOUSING |
| 3 | SCREWS FOR CABLE CLAMP | 10 | WALL PLUGS |
| 4 | TERMINAL BLOCK | 11 | WALL INSTALLATION PLATE |
| 5 | CAPACITOR | 12 | WALL INSTALLATION PLATE SCREWS |
| 6 | CABLE CLAMP | | |
| 7 | CABLE GROMMET | | |

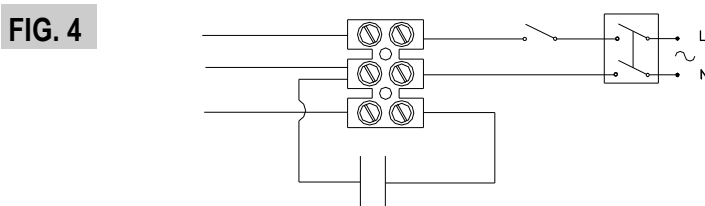
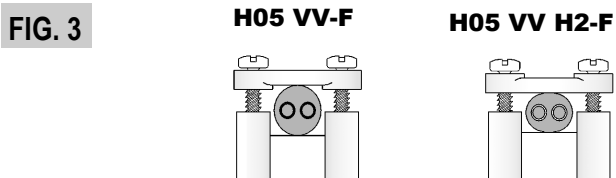
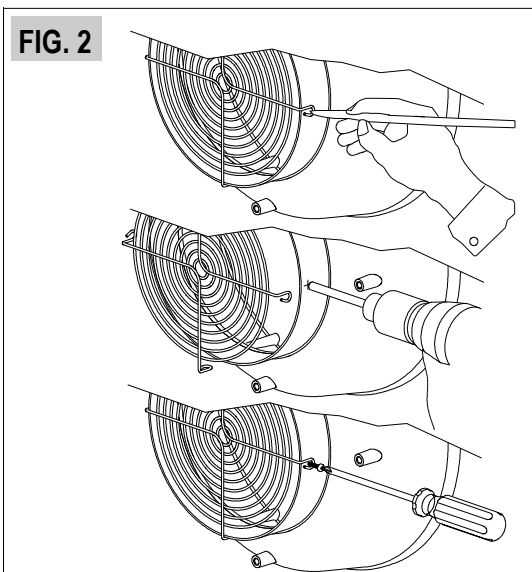
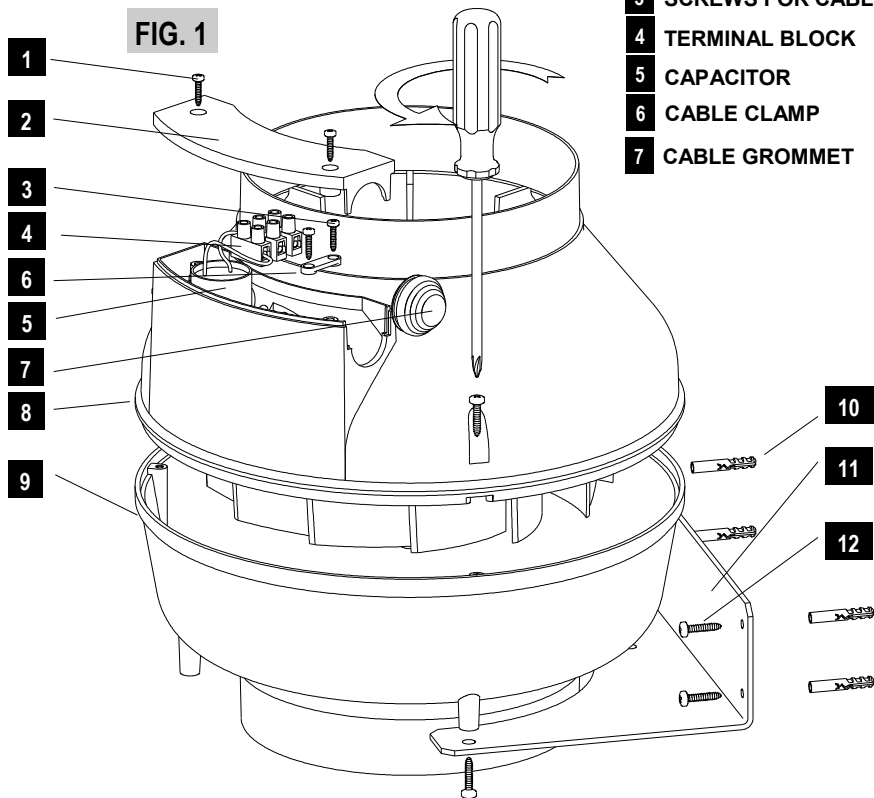

MAINTENANCE AND CLEANING

The motor and the fan blades shall be periodically controlled, usually afterwards every six months of continuous operation.

Maintenance shall be carried out just by qualified personnel.

Before any maintenance or cleaning operation, disconnect the appliance from the main power supply.

To clean the inside of the fan, use a soft brush taking care not to cause any damage to the electrical wiring.

During the normal cleaning operations, check the integrity of all appliance parts.

Vectaire Ltd.
Lincoln Road, Cressex Business Park, High Wycombe, Buckinghamshire, HP12 3RH, UK
Tel. +44 (0) 1494 522333 Fax +44 (0) 1494 522337