

'PPF4'

POSITIVE INPUT VENTILATION

for domestic properties to 200m³

- Whole House Ventilation System
- Low Noise Levels
- Easy to install on wall or ceiling
- Extremely Low Running Costs



ventilation



GENERAL FEATURES

- Positive pressure ventilation provides effective, draught free ventilation and prevents condensation forming
- Easy to install on wall or ceiling - the PPF4 can be used both in the refurbishment of older properties where condensation is a particular problem as well as in new build.
- The PPF4 introduces air into the dwelling to create a positive pressure.
- Fresh air is drawn in from outside, filtered and introduced into the living areas via a single grille.
- The fresh air circulates throughout the building giving draught-free ventilation and eventually dissipates via natural leakage.
- Runs continuously to provide a gentle influx of fresh air, maintaining a healthy and comfortable environment.
- Since the moisture content of the air outside is normally lower than that indoors, the level of humidity is reduced, helping to eliminate the damaging effects of condensation.
- A PPF4 allows extra security - there is no need to open windows.
- The noise level is extremely low.
- Wall or ceiling or mounted.
- The system is very economical and can cost less than £12 per year to run.

TECHNICAL FEATURES

- For domestic properties up to 200m³
- Easy wall, cupboard or ceiling installation - can be fitted horizontally or vertically.
- Choice of 3 speed levels (set at installation)
- Robust construction - steel cabinet lined with acoustic material - end covers from ABS plastic, and with white outer cover.
- Motor mounted on sealed for life self lubricating bearings
- Thermal overload protection
- Maximum ambient temperature 40°C
- Complete with fixing bracket
- Filtration to G3 standard.
- Easy to maintain - filter and motor/fan assembly can easily be accessed for cleaning (recommended approximately every six months) .
- Guaranteed for 2 years

COMPLIES WITH

- Part L1 2013 of Building Regulations for enhanced energy saving capability
- Part F 2013 of Building Regulations for reliable, efficient ventilation
- EU RoHS Directive Compliant.
- Conforms to requirements of EC Council directives relating to Electromagnetic Compatibility and Electrical Safety: 2006/95/CE (LVD), 2004/108/CE (EMC), EN 60335-2-80
- CE marked

AVAILABLE MODELS

PPF4 - positive pressure supply fan

Vectaire offers a design service to ensure that the unit installed is the best possible to provide efficient, effective, low energy and low running cost ventilation. Vectaire can also organise installation, commissioning and maintenance of these products

Model	Airflow - m ³ /hr at Speed			Airflow - l/sec at Speed			Watts at Speed			Volts	Hz
	1	2	3	1	2	3	1	2	3		
PPF4 with filter	40	79	110	11	22	31	10	24	36	230	50

nb: all above performances are WITH the filter in place

Dimensions - mm
Weight - 6kg

Overall dimensions with cover fitted:
150 x 260 x 495mm

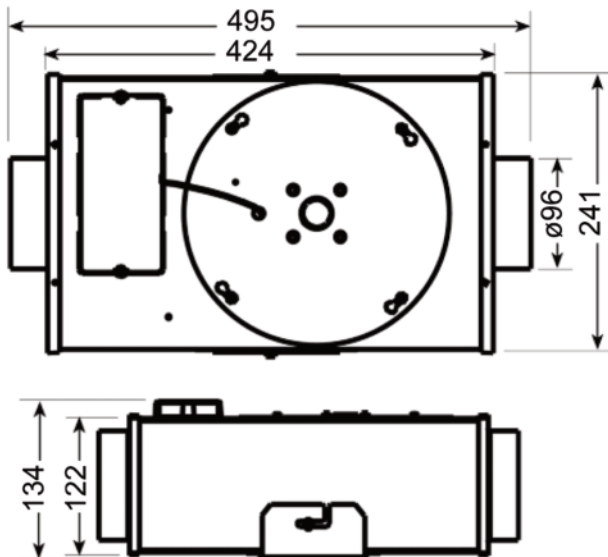

Typical Specification

Supply and install a PPF4 positive pressure fan supplied by Vectaire Ltd, Lincoln Road, Cressex Business Park, High Wycombe, Bucks, HP12 3RH.

This unit should be designed for easy cupboard or ceiling (or void) installation and should be able to be installed at any angle. It should be able to provide effective, draught free ventilation by introducing fresh air drawn in from outside and filtered before being introduced into the dwelling creating a positive pressure. The indrawn air is then dissipated through openings around the property, thus providing a constant, background air change.

The fan should have a choice of three speeds on installation and run automatically at that level (chosen according to the size of the dwelling). The fan should be supplied with a fixing bracket.

The fan should comply with all current IEE, EC and Building Regulations requirements and also be BRE Digest 398 compliant

Vectaire Ltd

Lincoln Road
Cressex Business Park
High Wycombe
Buckinghamshire
HP12 3RH

Tel: +44(0)1494 522333
Fax: +44(0)1494 522337

Email: sales@vectaire.co.uk
Web: www.vectaire.co.uk

