

**8. SPARES LIST**

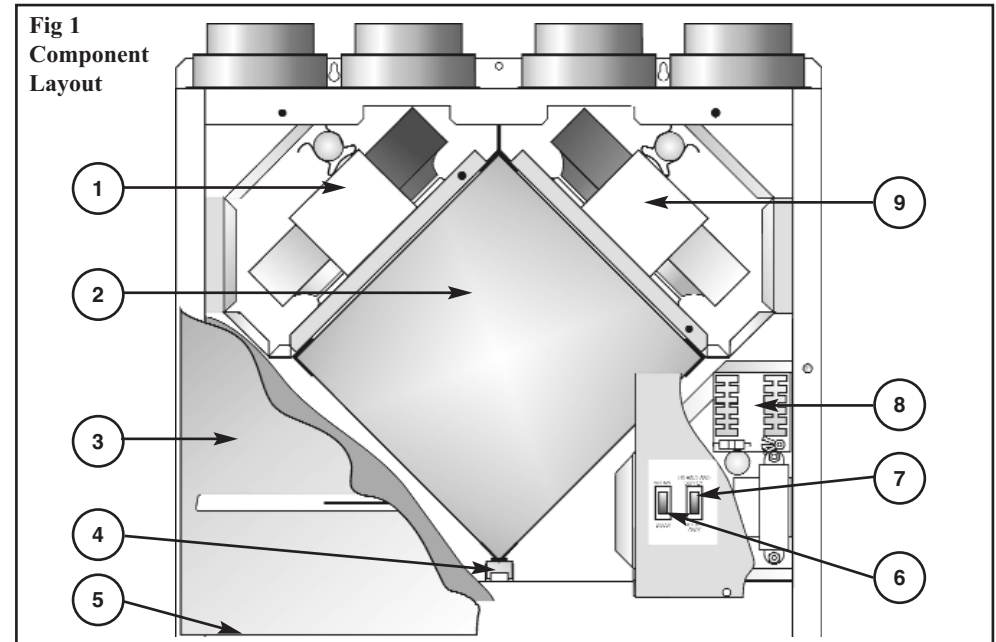
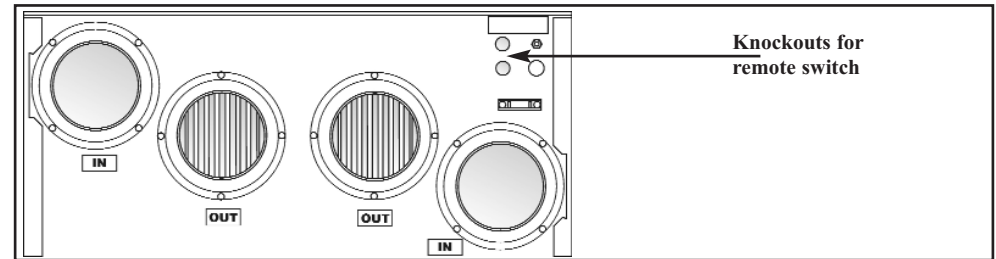
Item	Part Number	Description	Qty
1	1000-0522520	Air circulating fan (WHHR250)	2
	1000-0504780	Air circulating fan (WHHR150)	2
2	1000-0300170	Heat Exchanger	1
3	H250-0140000	Front decor panel (WHHR250)	1
	H155-0130000	Front decor panel (WHHR150)	1
4	H250-0112000	Sealing cover and gasket	1
5	1000-0506480	Transformer	1
6	1000-0514530	Switch	2
7	1000-0510750	Capacitor 3 $\mu$ f (WHHR250)	2
	1000-0504740	Capacitor 2 $\mu$ f (WHHR150)	2
8	1000-0516490	Humidistat (where fitted)	1

**WHHR150 and WHHR250 WHOLE HOUSE VENTILATION SYSTEM with HEAT RECOVERY INSTALLATION, COMMISSIONING AND SERVICING INSTRUCTIONS**



**1. GENERAL DESCRIPTION**

1.1 The WHHR150/250 systems provide whole house mechanical ventilation to living areas and bedrooms. Heat is recovered from stale contaminated air drawn from bathrooms and utility rooms in conjunction with stale air from the kitchen; drawn through a cooker canopy (if fitted). The WHHR250 uses a high performance heat exchanger that recovers heat and uses it to temper the incoming fresh air. The unit is supplied assembled for right hand configuration but may be changed to left hand configuration.



- 1. Fan
- 2. Heat Exchanger
- 3. Front decor panel
- 4. Locking wedge
- 5. Bottom Blanking plate (where fitted)
- 6. Normal/Boost switch
- 7. Extract & Supply/Supply switch
- 8. Terminal connector
- 9. Fan

Vectaire Ltd, Lincoln Road, Cressex Business Park, High Wycombe, Buckinghamshire, HP12 3RH  
 Tel: +44(0)1494 522333. Fax: +44(0)1494 522337. Email: sales@vectaire.co.uk. www.vectaire.co.uk

**1.2 COMPONENT CHECK**

Item	Description	Quantity
1	Heat Recovery Unit	1
2	Grommet	2
3	Installation, Commissioning and Servicing Instructions	1
4	User Instructions	1

**Ancillary Equipment**

HRVC1 Remote fan speed switch control 1

WHRCC Cooker Canopy (without fan)

**Note:** If the WHHR unit is to be used in conjunction with the cooker canopy, then other exhaust ducts must form part of the system to prevent the exhaust air inlet of the unit being sealed by closure of the cooker canopy vent. For loft installation free standing kit MK150 is required.

**Note:** For additional ancillary equipment (e.g. ducting, grilles etc.) contact the Sales Dept. at Vectaire Ltd.

**2. INSTALLATION**

- 2.1 Installation shall be in accordance with the current editions of:
  - Building Standards (Scotland) (Consolidation) Regulations.
  - Building Regulations.
  - BS5720: Mechanical ventilation and air conditioning in buildings.
  - BS7671: Requirements for Electrical Installations. Wiring Regulations.

2.2 The design, material Specification and Installation must only be carried out by “competent persons”.

2.3 **IMPORTANT: It must be ensured that flue gasses from fuel-burning equipment are not drawn into a living area. If any room where air is extracted contains a fuel burning appliance, such as a central heating boiler, then:**

- 2.3.1 its flue must be of the room sealed or balanced flue type, or,
- 2.3.2 allowance must be made for an adequate supply of air into the room.

2.4 **POSITIONING.**

2.4.1 The unit is best installed in a kitchen above the cooker, but if this is not practicable it can be positioned in the loft or any suitable location.

**NOTE:** Installation height is subject to local regulations, but the height (H) of a cooker canopy must not be less than 450mm from the top of an **ELECTRIC** cooker, or less than 700mm from the top of a **GAS** cooker (refer to Fig. 6).

2.4.2 When the unit is installed in the loft or a heated area, it may only be positioned on its back (as shown in Fig. 5).

2.4.3 It is not advisable to install the unit so that it is directly above a bedroom or living room ceiling, or in an area that is part of a living area or bedroom. If this is likely to cause a problem, please contact Vectaire Ltd.

2.4.4 Consideration must be given to access for servicing, as servicing of the fans and cleaning of the heat exchanger, which should be carried out annually.

2.5 **GENERAL PREPARATION**

2.5.1 The unit is supplied with 100/125mm spigots and for satisfactory operation of the unit where the airflow rate is above 120m<sup>3</sup>/hr, (see performance curves on page 8) it is recommended that the centre part of the spigot is removed and 125mm ducting used.

2.5.2 The centre part of the spigot can easily be removed by placing a flat piece of wood (or similar) over the centre part and applying a sharp tap with a hammer (see fig. 2)

**NOTE:** In situations where it is either not possible or not desirable to use 125mm ducting, 100mm ducting can be used but it **MUST** be noted that using the WHHR250 in ‘**BOOST**’ mode might increase noise levels.

2.6 **PREPARATION FOR INSTALLATION ABOVE A COOKER CANOPY.**

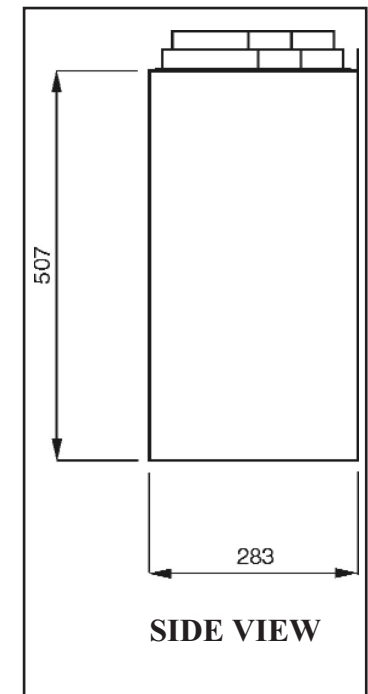
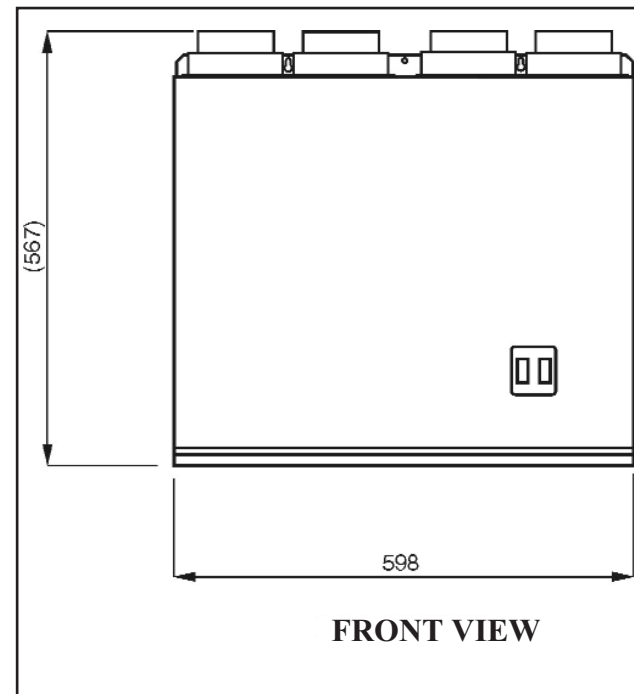
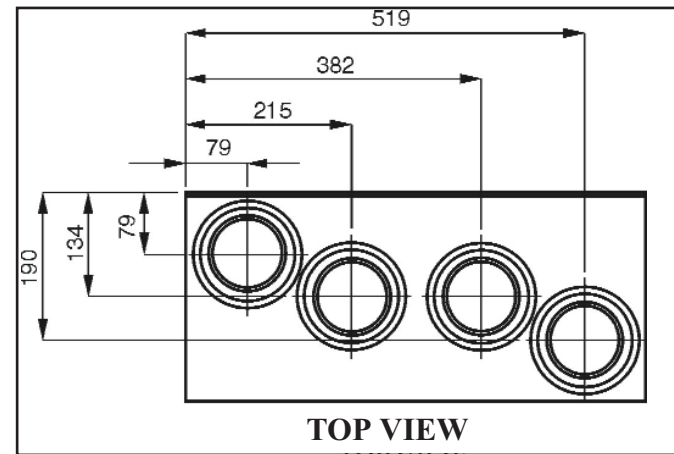
2.6.1 Remove the front decor panel by pulling it off the ball catches and lift the panel clear of the appliance. Remove the electrical cover panel to provide access to the electrical connections.

2.6.2 With reference to Figs. 3 & 4 decide whether the unit is to be installed in the right or left handed configuration. If the handing of the unit is to be changed, proceed as follows:

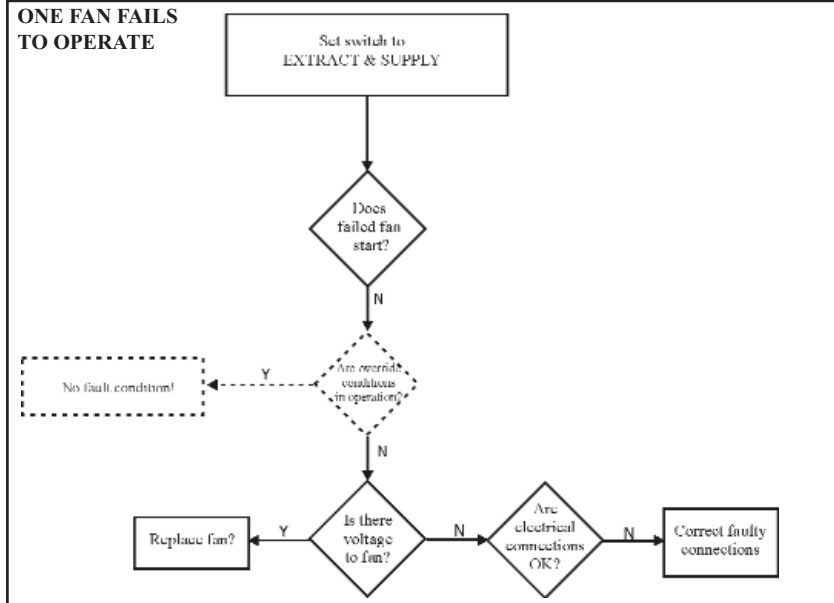
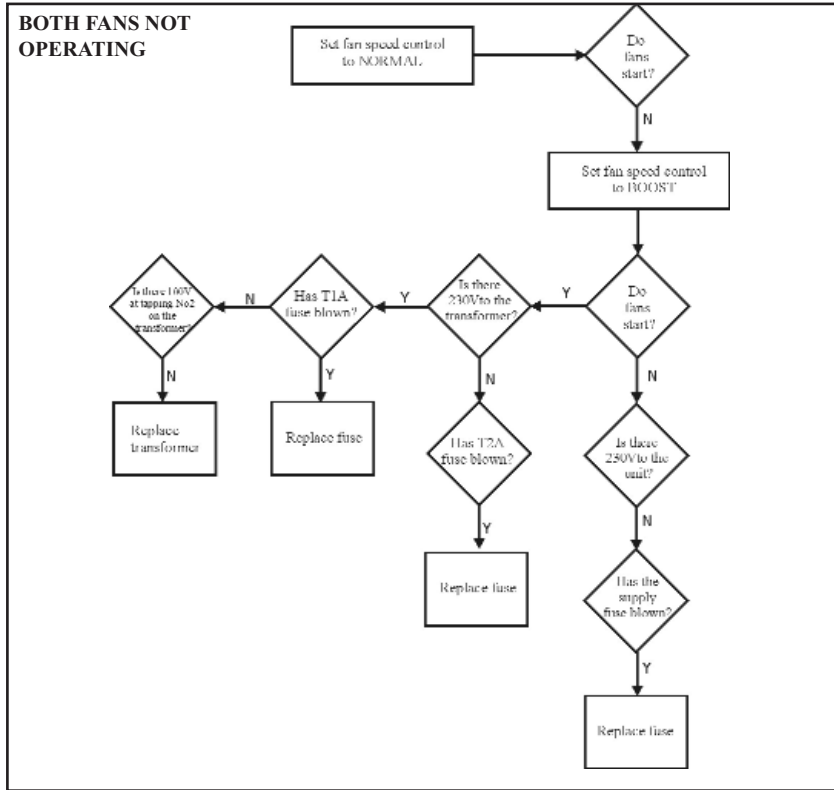


**Fig 2**  
Use a block of wood and hammer to tap out 100mm spigots

rec-



7. DEFECT DIAGNOSIS



- Remove the four screws securing the blanking cover on the base tray and transfer the cover to the other extract aperture
- Swap the positions of the condensate drain blanking grommet, and the condensate drain elbow fitting complete with plastic washer. Access to the drain elbow nut may be gained through the extract aperture.
- Referring to Fig. 10, interchange the following connections on the terminal block:  
**YELLOW** lead from terminal '5' to terminal '6'  
**BLUE** lead from terminal '6' to terminal '5'

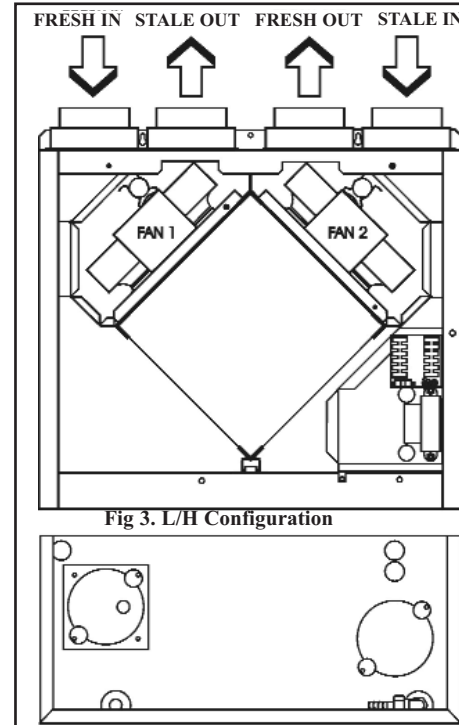


Fig 3. L/H Configuration

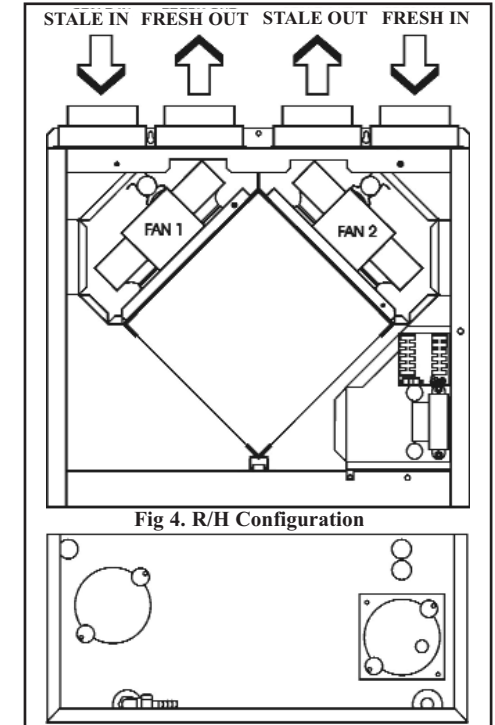


Fig 4. R/H Configuration

2.7 CONDENSATE.

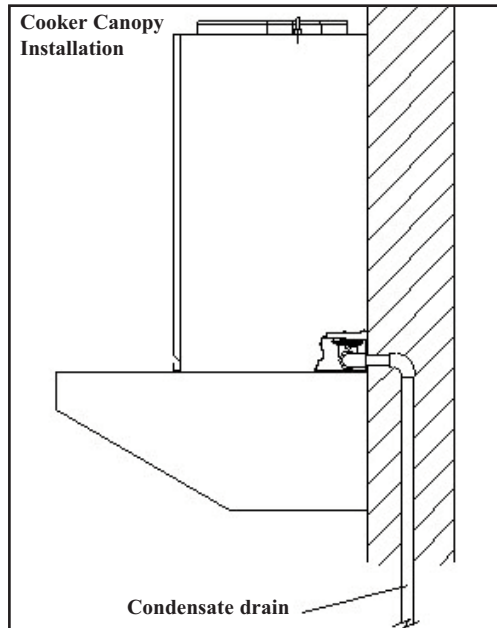
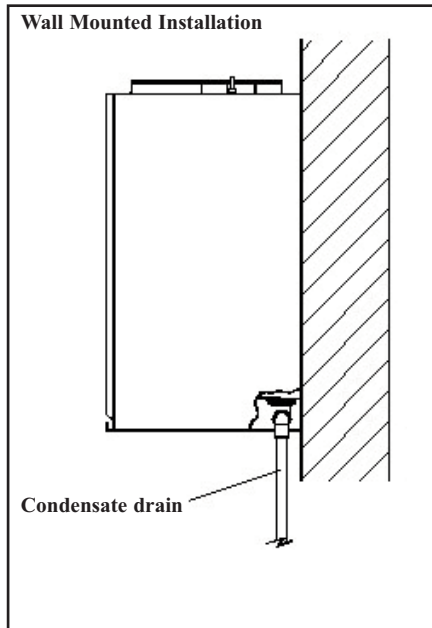
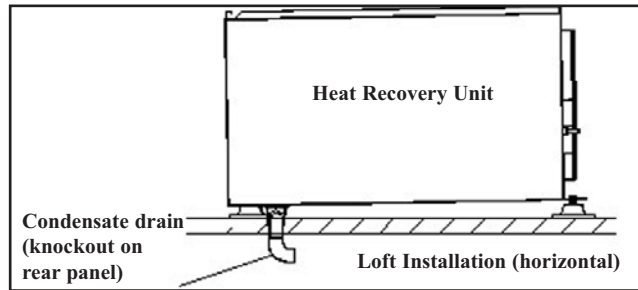
**IMPORTANT:** At times the unit might produce condensate which **MUST** be drained away. The unit is provided with a drain elbow allowing a condensate drain hose with a 10mm bore to be push connected.

- The drain pipe, which must have a continuous minimum fall of 6mm per 1m run, can either be chased into the wall or run downwards from the unit, to terminate outside the building into the nearest drain or gutter.
- In some instances a condensate connecting point will already be provided as part of the building design. The position of this point, relative to where the heat recovery unit is to be installed, is to be checked for any appreciable connection misalignment and necessary adjustment made before proceeding any further.
- Decide from which exit the condensate drain pipe is to be connected and remove the knockout from the appropriate side panel. If necessary, loosen the condensate elbow fitting, rotate it to face the knockout hole and re-tighten.

**Note:** both the WHHR150 and WHHR250 units are pre-configured for drainage from the left hand lower exit.  
**2.8 MOUNTING**(without Cooker Canopy, in areas other than a loft).

- Hang the unit onto the two top wall fixings. Mark through, drill and plug the remaining fixing holes.
- Referring to Fig. 5, determine the method to be used and make the condensate drain pipe connection to the unit.
- Secure the unit to the wall, using washers under the screw heads if necessary, and complete the condensate drain system.

**Fig 5**  
**Condensate**  
**Drain**  
**Routing**



**IMPORTANT: There must be a sufficiently large visible gap between the condensate drain pipe termination and the collection point, to prevent ice buildup.**

2.8.4 Fit the blanking plate to the base of the unit and secure using 8 of the self tapping screws provided.

### 2.9 MOUNTING (in conjunction with a Cooker Canopy)

**Note: Refer to the Instructions provided with the Cooker Canopy.**

2.9.1 Referring to Paragraph 2.4.1 and Fig. 6, determine the height (H) of the cooker canopy from the cooker top. Mark the base datum line for the Heat Recovery unit at H + 150 mm.

2.9.2 Position the WHHR unit such that the base of the unit aligns with the base datum previously marked and mark the position of the 2 x keyhole fixing points. Remove the WHHR unit.

**Note: It is important that the unit is mounted perfectly horizontally, in order that the condensate drain shall function effectively.**

2.9.3 Drill and plug the 2 x fixing holes and secure the Heat Recovery unit to the wall using suitable screws (not provided).

**Note: For wall types other than masonry, prepare the wall to suit a purpose made fixing.**

2.9.4 Referring to Fig. 1, remove the front decor panel and gain access to the electrical panel by removing the electrical panel cover.

2.9.5 Referring to the Installation and User Instructions, fit the Cooker Canopy to the wall and the underside of the WHHR unit.

5.3.4 If the airflow is still too low (the unit is factory set to provide a minimum airflow), proceed as follows:

- Turn the electrical supply OFF,
- Remove the electrical cover panel,
- Locate the voltage selector (see fig. 10) and transfer the flying lead to the next connection on the terminal block,
- Refit the electrical cover panel,
- Turn the electrical supply ON.

5.3.5 Re-measure the airflows at the grilles or valves as detailed in para 5.3.3, and repeat the procedure until the correct airflows are achieved.

5.3.6 Set the fan speed control to 'BOOST' and ensure that the airflows increase.

5.3.7 If the unit is installed with a warm air heater, the airflow is to be set by taking measurements at the extract grilles or valves.

## 6. SERVICING

**IMPORTANT: Before commencing any servicing or component replacement, ensure the ELECTRICAL SUPPLY to the unit is ISOLATED.**

Cleaning of the extract and supply fans and heat exchanger is required annually. Filters on the cooker canopy or kitchen extract may require cleaning more frequently. Clean in accordance with their relevant instructions.

### 6.1 HEAT EXCHANGER REMOVAL AND SERVICING:

6.1.1 Remove the front decor panel. Release the 6 screws securing the sealing cover, swing the electrical cover panel forward and remove the sealing cover, taking care to avoid damage to the gasket.

6.1.2 Release the heat exchanger by withdrawing the wedge at the bottom of the heat exchanger, and remove the heat exchanger from the unit, taking care to avoid damaging the heat exchanger air passages.

6.1.3 Check that all the air passages are free from obstruction. If not, clean by washing in a soapy solution, or with a light brush.

**Note:** Under no circumstance must any sharp implement, that is likely to distort or puncture the air passage walls, be used.

6.1.4 Refitment or replacement is in reverse order. Ensure that the retaining wedge firmly secures the heat exchanger.

### 6.2 FAN ASSEMBLY REMOVAL AND SERVICING:

6.2.1 Referring to section 6.1, remove the heat exchanger.

6.2.2 Disconnect the wiring from the electrical panel to the fan, at the fan terminal block.

6.2.3 Release the 4 screws securing the fan assembly to the heat exchanger compartment, and withdraw the fan assembly.

6.2.4 Remove all dust etc. from both the impeller and the motor, taking care not to disturb the balance of the fan.

6.2.5 Refitment or replacement is in reverse order.

### 6.3 TRANSFORMER REMOVAL:

6.3.1 Remove the front decor panel and electrical cover panel.

6.3.2 Disconnect the transformer conductors from the electrical panel terminal block, noting their positions.

6.3.3 Release the 2 screws and washers securing the transformer to the electrical compartment, and withdraw the transformer.

6.3.4 Refitment or replacement is in reverse order.

### 6.4 SWITCH REPLACEMENT:

6.4.1 Remove the front decor panel and electrical cover panel.

6.4.2 Note the position of the three conductors to the switch for reconnection purposes, and disconnect the conductors from the switch.

6.4.3 Remove the switch by depressing the retaining springs at the top and bottom of the switch and withdraw the switch from the electrical cover panel.

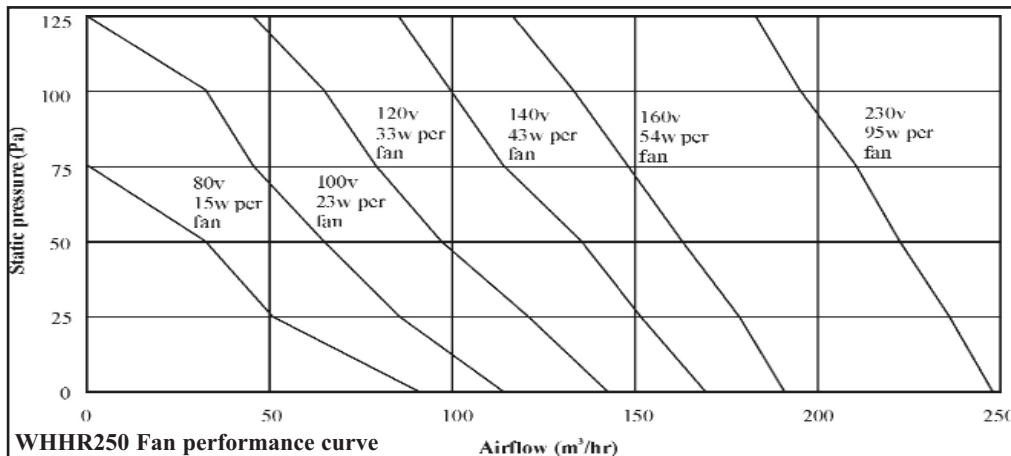
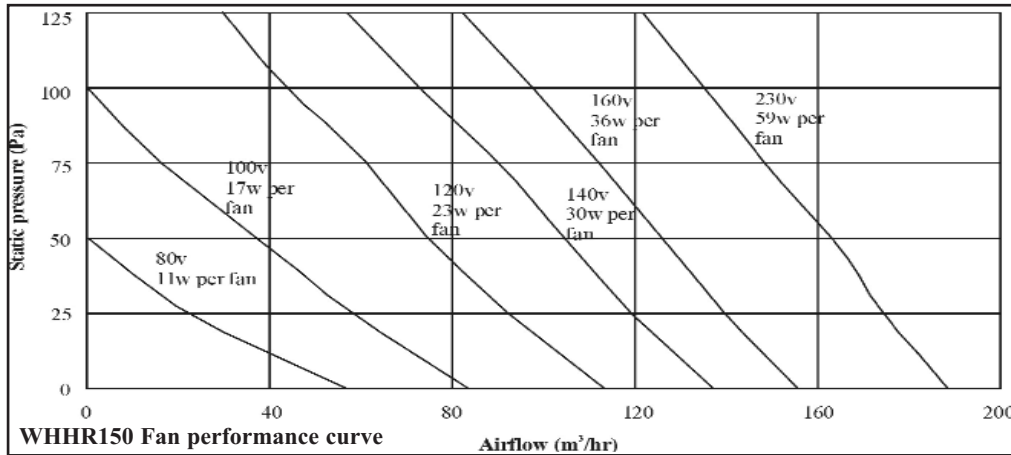
6.4.4 Replacement is in reverse order.

### 6.5 SYSTEM MAINTENANCE:

6.5.1 Clean any in-line filter that may be fitted in accordance with the filter's instructions.

6.5.2 Clean the kitchen extract grille filter (if fitted) by washing in a soap solution.

6.5.3 Clean the filter in the cooker canopy (if fitted) in accordance with the instructions provided with the cooker canopy.



**5. COMMISSIONING**

- 5.1 The unit operates by extracting warm, stale air from kitchens, toilets/bathrooms etc., passing it through a heat exchanger and out to atmosphere. A second fan draws in cool fresh air and passes it through the same heat exchanger where it absorbs heat from the outgoing stale air. Refer to Table 2 for switch functions.
- 5.2 The unit must be set up as detailed in section 5.3, so that the NORMAL setting on the fan speed control (see Fig. 7) enables the INLET fan to deliver the designed volume airflow. The switching from NORMAL to BOOST allows the unit to extract at a greater rate to cope with any increase in the build up of condensation or foul air, e.g. when cooking etc.
- 5.3 Before commencing the commissioning procedure, refer to the design drawing for correct air flows.

**Note: Extract air and supply air volumes will not always be equal, therefore, when setting up, the extract system should be the datum.**

- 5.3.1 Ensure that the exhaust and supply grilles or valves are open.
- 5.3.2 Turn the electrical supply ON, and set the fan speed control to 'NORMAL'.

**Note: If the fans do not start, refer to the defect diagnosis charts on page 10**

- 5.3.3 Check the airflows at the grilles or valves, and adjust to suit the design figures by turning the centre of the grille clockwise to decrease the airflow, and anticlockwise to increase the air flow.

2.9.6 Referring to Fig. 9, connect the canopy electrical cable as follows:

- Brown** connector to Terminal Block TB3 terminal marked 'L',
- Blue** connector to Terminal Block TB3 terminal marked 'N',
- Green/Yellow** connector to the common **Earth Point**.

2.9.7 Refit the electrical panel cover and decor panel to the heat recovery unit.

**2.10 MOUNTING IN ALOFT**

A Mounting Kit is required for loft applications. These instructions are to be read in conjunction with those supplied with the Mounting Kit.

- 2.10.1 Connect the drainage hose to the condensate drain connection (see para. 2.7.1 for minimum fall) and ensure that steps are taken to minimise the risk of mechanical damage to the drainage pipework. Run the pipe internally as far possible and insulate to protect against freezing.
- 2.10.2 The drain pipe must terminate outside of the building and must be run as near vertical as possible into the nearest drain or gutter.

**IMPORTANT: There must be a sufficiently large visible gap between the condensate drainpipe termination and the collection point, to prevent ice build-up.**

**3. DUCT AND DUCT CONNECTIONS** (Refer to design drawing)

3.1 Four 100/125mm nominal diameter spigots are provided for connection of the ducting (see para. 2.5). These must be connected to the supply and exhaust ducts according to left or right hand configuration (refer to Figs 3 & 4).

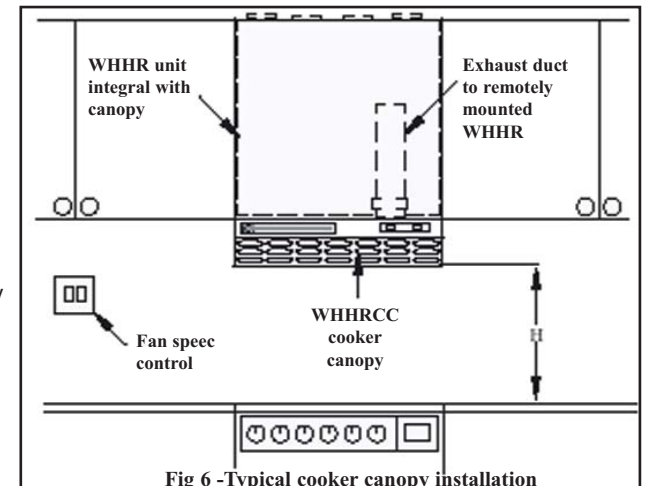
**Note: Flexible or rigid ducting may be used, but must fit OVER the spigots. If 25mm ducting is used, the 100mm section MUST be removed as shown at paragraph 2.5**

- 3.2 Where ducts are exposed in unheated areas, they must all be insulated with at least 25mm of polyurethane foam or equivalent, except for the exhaust duct from the unit to the atmosphere.
- 3.3 The duct layout must be designed to suit the requirements of the ventilation/recovery system and building layout, and suitable fire dampers MUST BE FITTED to protect against fire being transmitted through the ducting.
- 3.4 Where rigid ducting is used, it should be installed using the least number of fittings to minimise resistance to air flow. Where possible, final connection to grilles and the unit should be made with a flexible connection.
- 3.5 Where flexible ducts are used, ensure that:
  - 3.5.1 ducting lengths are kept to minimum;
  - 3.5.2 ducting is stretched so that it is smooth and straight;
  - 3.5.3 where bends are necessary, their radius is as large as possible to avoid sharp corners;
  - 3.5.4 where ducting is run in restricted areas, the ducting is not crushed.

3.6 The inlet for the fresh air supply can be direct from outside or from within a ventilated roof space. If the supply is direct from outside, it must have an external wall baffle fitted if supplied through a wall, or a recognised roof terminal if supplied through a roof.

3.7 The exhaust air must exit to outside through either a wall or a roof and must be protected by a wall baffle or recognised roof terminal.

3.8 Kitchen extracts must be filtered.



**4. ELECTRICAL**

**WARNING: THIS APPLIANCE MUST BE EARTHED. ALL WIRING MUST CONFORM TO INSTITUTE OF ELECTRICAL ENGINEERS (I.E.E.) REGULATIONS 488 (CURRENT EDITION).**

- 4.1 The unit is suitable for a 230V, 50Hz single phase supply fused at 3A.
- 4.2 The unit is supplied with a mains flexible cord (PVC sheathed, 3-core brown, blue & green/yellow 0.7mm<sup>2</sup> to BS6500,) connected to a terminal block and exiting through a grommet and cable clamp at the right hand top of the unit.
- 4.3 A fused spur box, or double pole switch having a minimum contact separation of 3.0mm, must be used to provide isolation for the unit.
- 4.4 **IMPORTANT:** If the unit is required oppositely handed to that supplied, then the **BLUE** (fan 1) and **YELLOW** (fan 2) leads to terminals 6 and 5 (respectively) must be swapped.
- 4.5 Installation notes for HRVC1 (remote fan speed control):
  - 4.5.1 If the WHHR is to be loft mounted, a remote fan speed control/summer switch (HRVC1) is required (see section 1.1). This will usually be situated in the kitchen and must be connected to the unit by 3-core and earth (CMA Ref. 6243Y) and 2-core and earth (CMA Ref. 6242Y) 1mm<sup>2</sup> PVC covered cable in accordance with the relevant wiring diagram (Fig. 8 or 9).
  - 4.5.2 The HRVC1 must not be mounted above, or closer than 1m to, the cooker where it could be affected by excessive heat and/or moisture.
  - 4.5.3 If the fan speed control/summer switch is to be fitted to a surface mounted control box, the box must not be mounted on a conductive unearthed metal panel or decorative tile, and must include a suitable earth terminal for terminating the cable.
  - 4.5.4 The wiring to the switches incorporated in the unit must be removed in its entirety and the remote switched wired to the terminal strip, via the knockouts in the top of the unit (refer to Fig. 1), using the grommets supplied in the HRVC1 kit. Connections are to be in accordance with the relevant wiring diagram.

**Note: The switch terminal markings differ according to manufacturer. Referring to Fig. 8 or 9:  
 On RPP switches: 0 = 2W, 1 = 1W  
 On MK switches: 0 = L1, 1 = L2.**

Connections from the remote switch to the terminal block are as follows:

VENTILATION SWITCH	SUMMER VENTILATION SWITCH	TERMINAL BLOCK
0	-	7
1	-	3
-	0	6
-	1	-
COMMON	COMMON	7

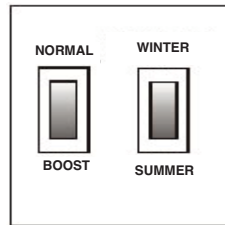


Fig 7 Fan Speed Control

SWITCH POSITIONS		FUNCTION
VENTILATION	SUMMER VENTILATION	
Normal	Winter	Both fans running at normal speed
Boost	Winter	Both fans running at full speed
Normal	Summer	INLET fan stopped. EXTRACT fan running at normal speed
Boost	Summer	INLET fan stopped. EXTRACT fan running at full speed

- 4.6 **IMPORTANT:** If the higher speed "boost" facility is required to be operated by an alternative type of switching device, eg a light switch, a PIR or humidistat, then the HRVC1 must be replaced by an external relay (not included, but can be supplied by Vectaire as an optional extra). If this alternative is chosen, the Summer/Winter feature cannot be used.

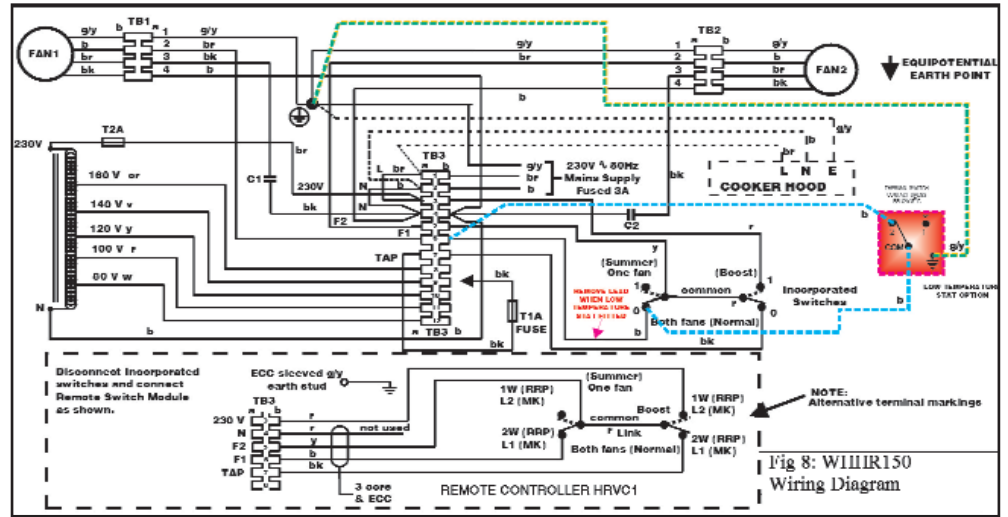


Fig 8: WHHR150 Wiring Diagram

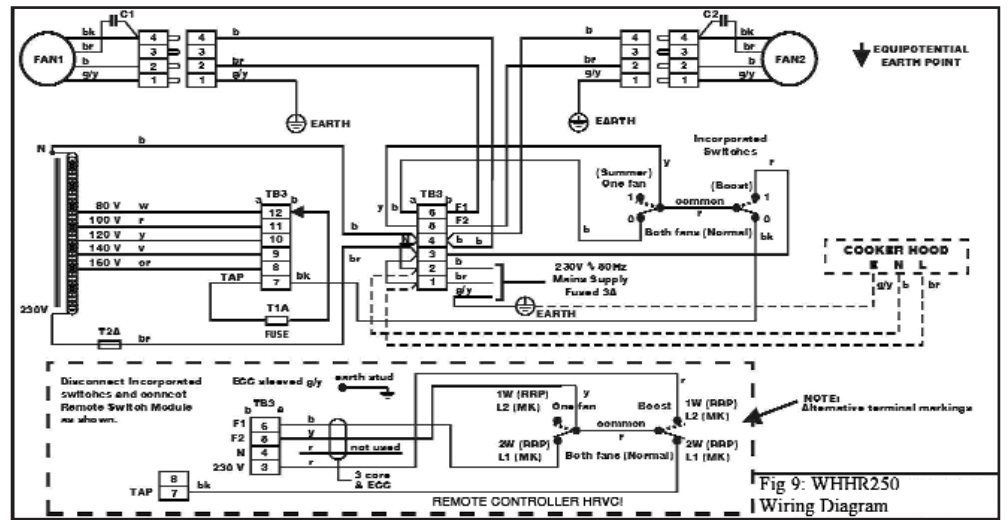


Fig 9: WHHR250 Wiring Diagram

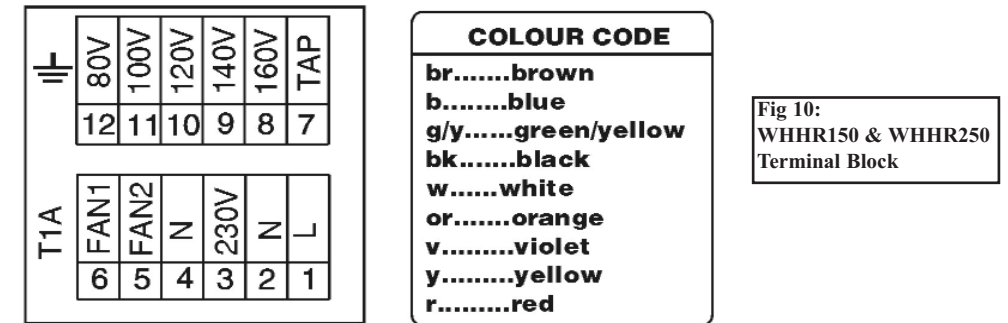


Fig 10: WHHR150 & WHHR250 Terminal Block