

WHHR200/90DC

WHOLE HOUSE HEAT RECOVERY UNIT

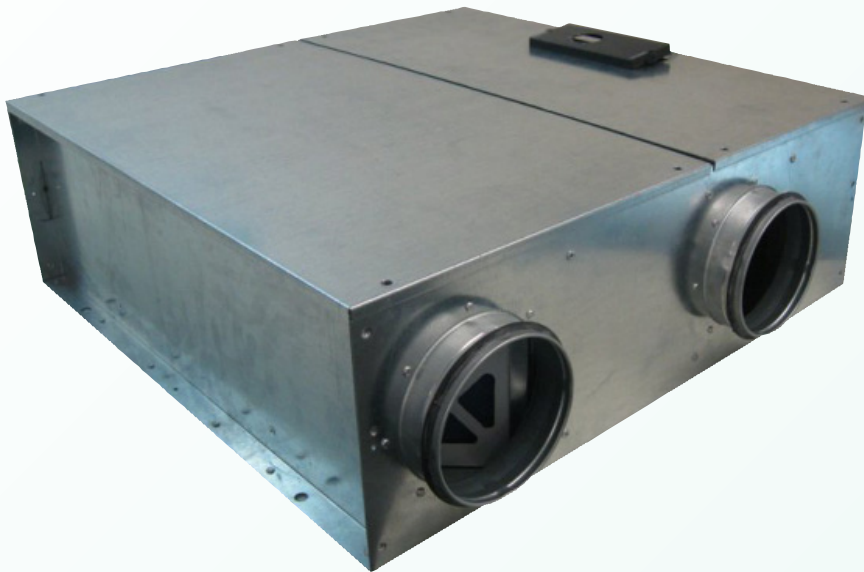

FEATURES

- Highly efficient, low energy solution to condensation and pollutant control
- Continuous ventilation in kitchen plus up to 6 additional wet rooms
- Up to 90% heat exchange efficiency
- Low noise levels
- Building Regulations Part L and Part F compliant

GENERAL

- Whole House Heat Recovery unit for larger homes and offices
- continuous ventilation in kitchen and up to 6 additional wet rooms
- maximum airflow 430m³/hr
- suitable for areas up to 250m²
- over 90% of heat is recovered from air extracted from warm, moist rooms to create a stable, comfortable, healthy environment
- easy to install and maintain
- for fitting into lofts, voids, false ceilings or cupboards (can be angled horizontally or vertically)
- multiple choice low (trickle) speed and boost options - factory set at most usual requirement but can be adjusted by installer
- boost speed obtainable by user via remote switch/pull cord (ie a volt free contact switch - not supplied) **or** by a humidistat, thermostat, or PIR sensor using an intermediate, external relay (available separately)
- has integral over-run timer for boost speed
- low noise levels
- low running costs
- gives extra security by removing need to open windows
- guaranteed for 3 years
- Vectaire Ltd can supply all accessories for use with these units, including ducting and metal filters, outside grilles and wall cowl

SPECIFICATION

- compact, low profile unit
- casing manufactured from sheet steel lined with 25mm thick acoustic "O" class foam
- low energy DC external rotor motor has sealed for life bearings
- impellers are single width, single inlet, direct drive and backward curved for higher efficiency
- will not overload when encountering ductwork pressure
- easy plug-in connection cable
- operates in temperature up to 80°C
- uses standard, disposable G3 filters
- counter flow heat exchanger with aluminium plates for greater efficiency, superior separation of air and longer life

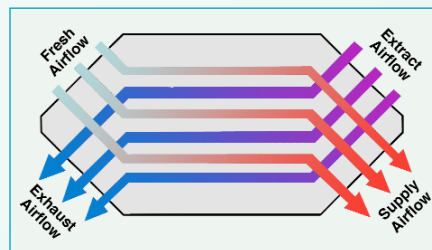

COMPLIES WITH

- Part L of Building Regulations for enhanced energy saving capability
- Part F of Building Regulations for reliable, efficient ventilation
- built to BS EN ISO 9001
- complies with IEC 60335-2-80, LVD2006/95/CE and EMC 2004/108/CE European Directive against radio interference and electro-magnetic compatibility
- CE marked

LOFT OR VOID INSTALLATION

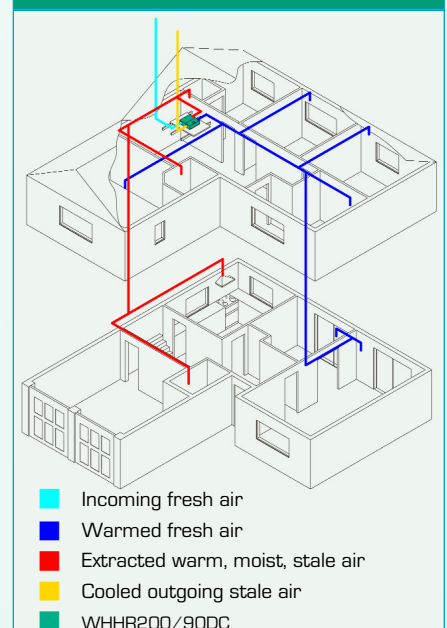

WHHR200/90DC - TECHNICAL INFORMATION

PERFORMANCE

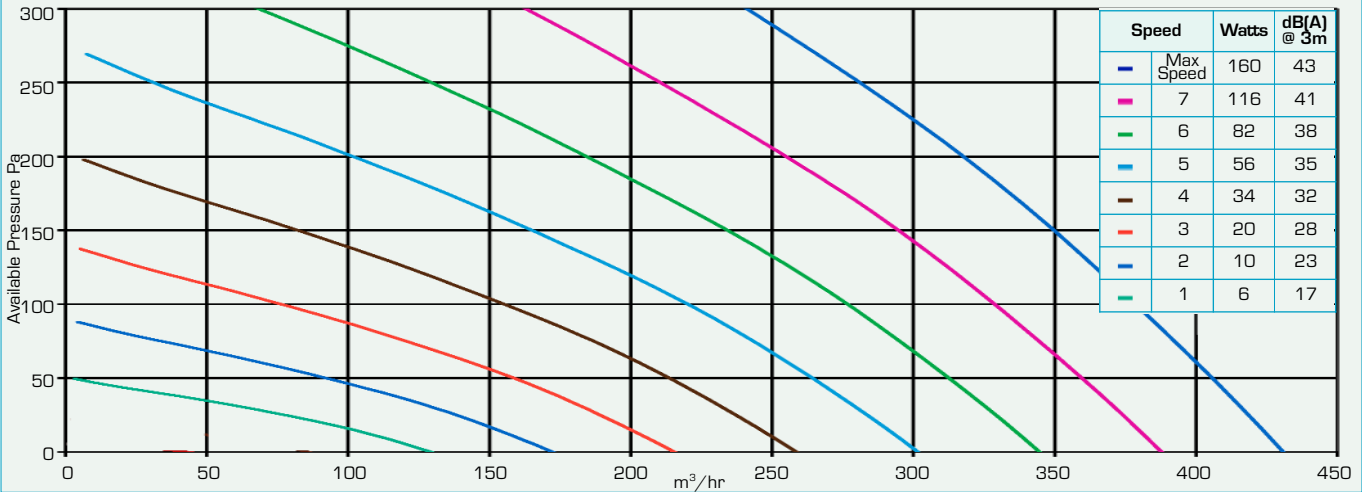

EFFICIENCY

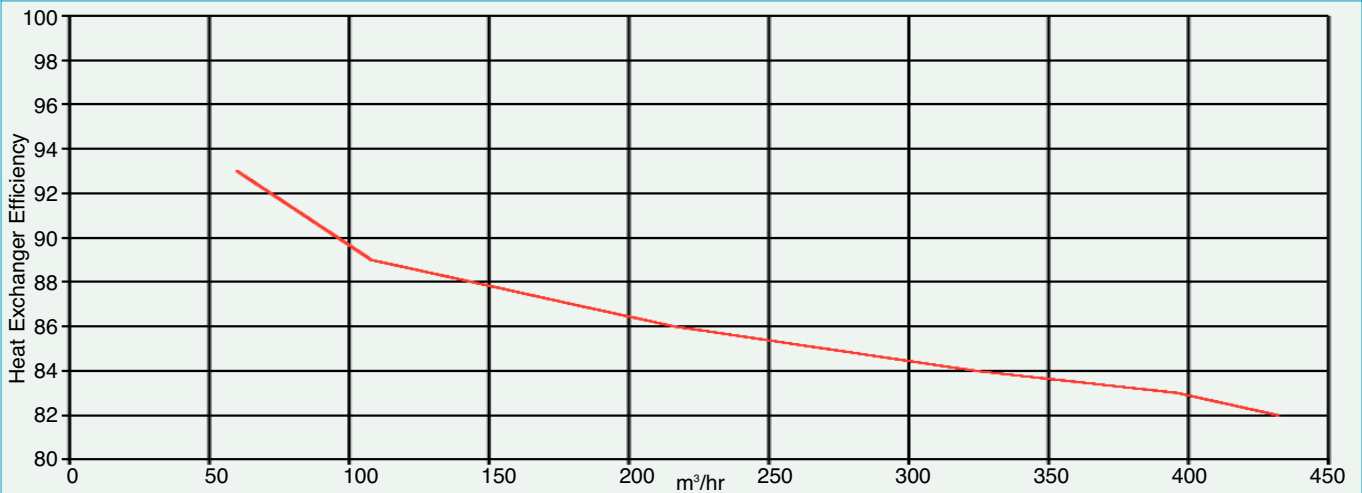

DIMENSIONS - mm

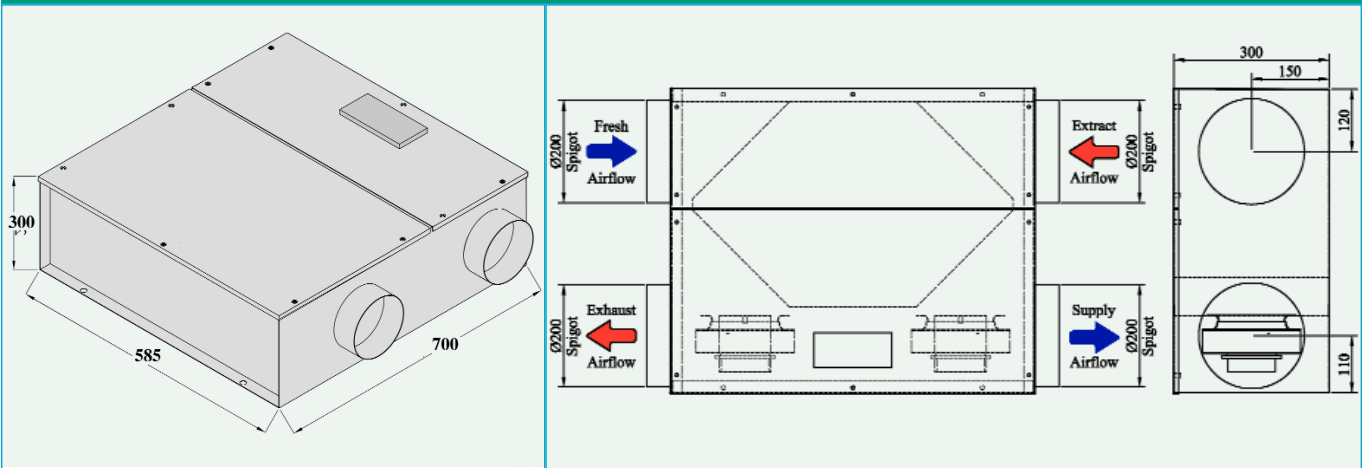

Vectaire Ltd
 Lincoln Road
 Cressex Business Park
 High Wycombe
 Buckinghamshire
 HP12 3RH
 Tel: +44(0)1494 522333
 Fax: +44(0)1494 522337
 Email: sales@vectaire.co.uk
 Web: www.vectaire.co.uk

